

The DataPlus+ range from Chubb safes has been expertly designed to ensure you have the best protection for your vital data media now with extra capacity



DataPlus+

FIRE-RESISTANT DATA MEDIA PROTECTION

Key Features

- Easy slam action emergency closing in event of a fire.
- Generous capacity. Chubb safes cabinets have been designed to give you more for your money than most other manufacturers' cabinets.
- High-quality media protection.
- Two-hour data media protection label. Tested to the highest international standards, UL 72 and EN 1047-1. EN Norm is certified by ECB•S in class S 120 DIS for fire resistance.
- Burglary protection in accordance with European norm EN 14450 and certified by ECB•S in security class S2.
- Easy to transport and install.
- Low weight ratio due to new advanced fire protection barrier material.
- Ability to customise by using internal fittings to optimise your storage capacity.
- Removable front plate allows useage of a pallet loader for more efficient installation, reducing costs to the customer.
- Ability to base fix to the floor for effective prevention of physical removal.
- The cabinet is fitted with a key lock as standard. However, you may require the monitoring of access to your sensitive data and therefore we have a series of electronic locks ranging from basic locking to more sophisticated audit trails.
- The cabinet is an attractive light grey which fits in well in most office interiors.



Chubb safes
Trusted the world over.

DATA PROTECTION

Capacity Chart

Media designation	Size f Dimension g (mm)	Per shelf (level)		Storage	Model									
		Size 1-4	Size 5		Size 1		Size 2		Size 3		Size 4		Size 5	
					No. of shelves	Total capacity	No. of shelves	Total capacity	No. of shelves	Total capacity	No. of shelves	Total capacity	No. of shelves	Total capacity
Magnetic discs:														
DLT tapes	110 x 112 x 30	48	94	F + L	4	192	7	336	9	432	13	624	13	1222
LTO tapes	110 x 112 x 30	48	94	F + L	4	192	7	336	9	432	13	624	13	1222
DDS 4 mm (DC 4)	80 x 58 x 16	124	239	F + L	8	992	12	1488	16	1984	22	2728	22	5258
DDS 8 mm (DC 8)	102 x 68 x 20	79	148	F + L	7	553	10	790	14	1106	19	1501	19	2812
DAT cassettes	80 x 60 x 15	134	260	F + L	8	1072	12	1608	16	2144	22	2948	22	5720
Data cartridges 3.5"	96 x 100 x 12	144	274	F + L	5	720	7	1008	10	1440	14	2016	14	3836
Data cartridges 5.25"	141 x 159 x 17	69	130	F	3	207	4	276	6	414	9	621	9	1170
AIT data cartridge (Sony)	67 x 112 x 21	108	216	F + L	4	432	7	756	9	972	13	1404	13	2808
Travan data cartridge (Sony)	78 x 100 x 19	100	212	F	5	500	7	700	10	1000	14	1400	14	2968
On Stream ADR (Verbatim)	129 x 95 x 15	89	162	F + L	5	445	7	623	10	890	14	1246	14	2268
SLR / MLR 5.25" (Imation)	116 x 161 x 21	54	126	F + L	3	162	4	216	6	324	9	486	9	1134
PD Cartridge (Fuji)	135 x 124 x 8	153	227	F + L	4	612	6	918	8	1224	12	1836	12	2724
IBM 3480 / 3490	127 x 110 x 25	51	99	F + L	4	204	7	357	9	459	13	663	13	1287
Optical and Magnetic discs:														
CD / DVD (R, RW and RAM)	142 x 124 x 10	117	225	F	4	468	6	702	8	936	12	1404	12	2700
Diskette 3.5 (floppy disc)	94 x 90 x 3.0	596	1124	F + L	5	2980	8	4768	11	6556	15	8940	15	16860
Optical disc 3.5	94 x 90 x 6	296	560	F + L	5	1480	8	2368	11	3256	15	4440	15	8400
Optical Disc 5.25	135 x 153 x 11	112	214	F + L	3	336	5	560	6	672	9	1008	9	1926
ZIP disc media	103 x 104 x 12	135	256	F + L	5	675	7	945	10	1350	14	1890	14	3584
MO - R/W (magneto-optical disc)	157 x 143 x 16	62	122	F + L	3	186	5	310	7	434	10	620	10	1220

F = frontal loading
F + L = frontal and lateral loading

Internal Fittings

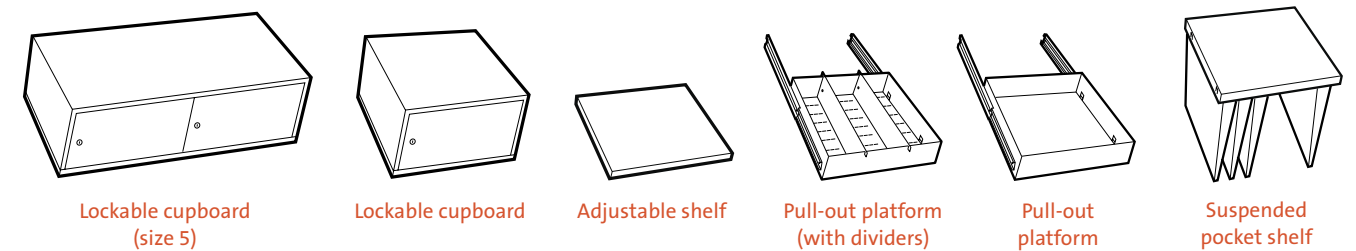

Authorised dealer

Chubb safes
Trusted the world over.

www.chubb safes.com

'Chubb' is owned by Chubb plc and is a registered trademark used under license

Product Specifications

Model	External (mm)			Internal (mm)			Fittings					
	Height	Width	Depth***	Height	Width	Depth	Internal Volume (litres)	Weight* (kg)	Adjustable shelf	Pull-out platform	Suspended pocket shelf	Lockable cupboard
Size 1	911	746	780	565	490	400	111	315	•	•	•	•
Size 2	1191	746	780	845	490	400	167	390	•	•	•	•
Size 3	1471	746	780	1125	490	400	221	490	•	•	•	•
Size 4	1941	746	780	1595	490	400	313	640	•	•	•	•
Size 5	1941	1036	830	1570	780	450	556	860	•	•	•	•**

* Weight refers to an empty cabinet

** A double cupboard is available for size 5 only

*** Gross measurement inc. 60mm for handle which can be removed for installation

All information supplied was accurate at the time of printing, however, Chubb safes reserves the right to make any modifications.

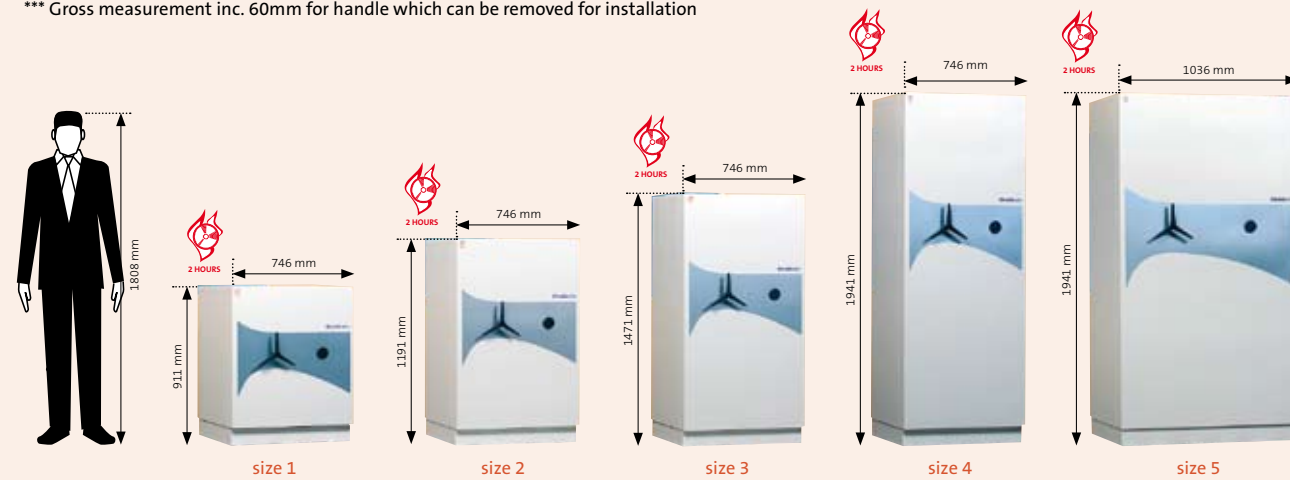

Installation Guide

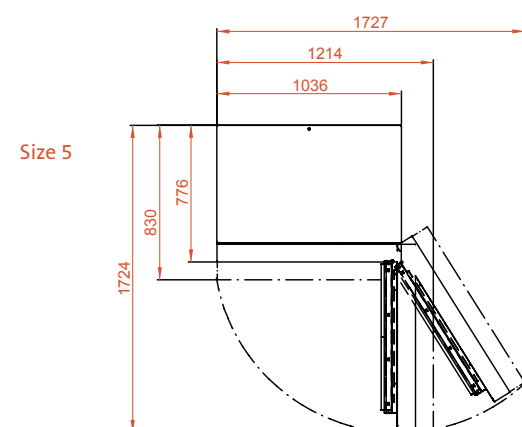
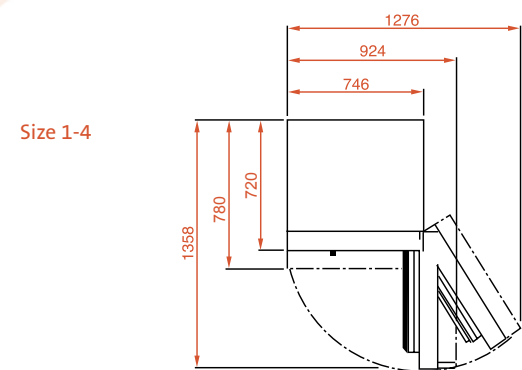

Lock Options

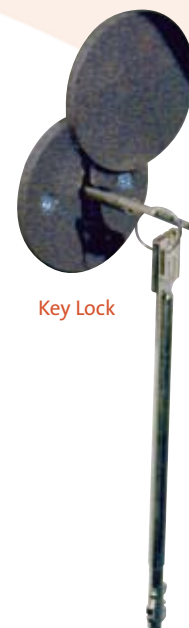

Key Lock



Electronic Lock

Fire Testing

The data media cabinet DataPlus+ is tested and certified by ECB•S according to the European standard EN 1047-1 in class S 120 DIS for two hour's fire protection. The test is carried out in two parts.

Fire test

Stage 1

The cabinet is placed inside the furnace which is heated to a temperature of over 1000 °C.



Stage 2

After 60 minutes in the furnace the burners are switched off. The inner temperature and humidity in the cabinet are continually monitored until the cabinet begins to cool. The cabinet remains in the furnace as the temperature returns to zero, then the cabinet is removed and opened. The maximum internal temperature inside the cabinet must not exceed 52 °C.



Impact test

Stage 1

The cabinet is placed in a pre-heated oven for up to 45 minutes. Then the cabinet is removed and dropped 9.15 metres onto a bed of rubble.



Stage 2

The cabinet is then placed back into the furnace for up to another 45 minutes. As it cools inside the furnace, the cabinet's temperature is monitored before being removed and opened. The maximum internal temperature must not exceed 52 °C.



Consequences of a fire

The picture illustrates the devastation caused by a fire. Imagine what would be left of your vital data media if it were not stored in a Chubb safes cabinet.

