

Chubb safes Record Protection Filing Cabinets provide fire protection for any paper based documents in the event of a severe fire. It is tested and certified to the Underwriters Laboratories test standard UL 72 Class 350 (Fire Endurance Test) for paper protection against fire.



RPF Cabinet 5200 Series

FIRE-RESISTANT DOCUMENT PROTECTION

Key Features

- Body** – The Body has an overall thickness of 57mm insulated with Chubb safes patented PCDE fire resistant material. Proofing materials used are also asbestos-free, reliable, stable, well aerated and will not deteriorate with age.
- Drawer** – The drawer is constructed with an overall thickness of 56mm. The proofing material is identical to the material used in the body of the cabinet. Each drawer is also suspended on full extension rails with bearings for durability and for ease of use. The drawers have been designed to fit most paper hoist and box files.
- Locking** – The Chubb safes RPF cabinet comes in 2 locking variants:
 - Central Locking** – One 3-wheel keyless combination lock and one key lock on the top drawer; controlling all drawers.
 - Individual Locking** – One 3-wheel keyless combination lock and key lock on the top drawer; controlling all drawers. In addition, there is one key lock on each subsequent drawer for individual locking.
- Fire Resistance** – Comes with 2 hours fire rated in compliance to UL 72 Class 350 (Fire Endurance Test) which represents one of the highest and most stringent test currently used to evaluate record protection equipment.
- Finish** – A scratch resistant Polyurethane based finish.



Chubb safes
Trusted the world over.

DOCUMENT
PROTECTION

Product Specifications

Model	External (mm)					Drawer's Internal Dimension (mm)			Nett weight (Kg)
	(A) Height	(B) Width	(C) Depth	(D) Clear depth over furniture	(E) Furniture Projection	(F) Height	(G) Width	(H) Depth	
5202 - 2 Drawers	839	551	824	1480	40	292	387	645	200
5203 - 3 Drawers	1206	551	824	1480	40	292	387	645	270
5204 - 4 Drawers	1573	551	824	1480	40	292	387	645	350

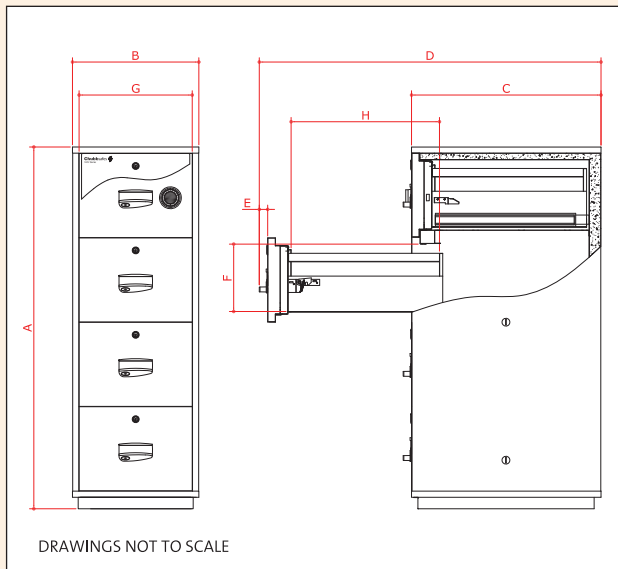

Keyless Combination Lock



Key Lock

Keyless Combination Lock

Secured by one 3-wheel Keyless Combination Capable of 1,000,000 changes of code. The operation of this lock is simple. The code can be changed easily.

Locking Option:

Electronic Lock



UL - 72 Class 350 Fire Endurance Test

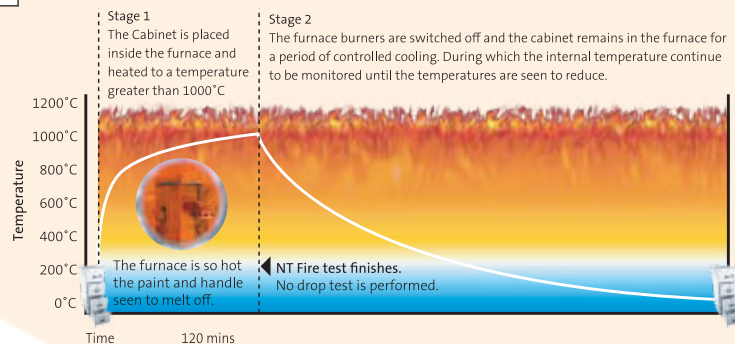

As the cabinet is affected by heat for a much longer time, the testing period can actually take up to 24 hours.

Testing in Compliance to UL 72 Class 350

Fire Endurance Test

The RPF Cabinet is placed inside a furnace and heated to 1010°C for 2 hours (5200 series) and is left to 'soak-out' to simulate an 'after fire' environment. The Cabinet has been designed to limit the internal temperature to not more than 177°C.



4 Drawers RPF Cabinet comes with Individual Locking



A Chubb Safes cabinet in the furnace showing its resistance to temperatures over 1000°C for upto 2 hours.



"This product is classified to UL Standards and requirements by Underwriters Laboratories Inc."
UL 72 Class 350

Note:

These products are designed primarily to provide protection against fire and impact for paper documents. For recommended storage of computer-based media, ask for details of Chubb Safes Data Cabinet. For protection against physical attacks, ask for details of Chubb Safes' safes.

Authorised dealer:

Chubb Safes
Trusted the world over.

GUNNEBO MALAYSIA SDN. BHD. (877658-K)
Suite 13A.01, Level 13A,
Menara Summit,
Persiaran Kewajipan, USJ 1,
47600 Subang Jaya, Selangor
Tel : +603-8024 3050
Fax : +603-8024 3051
Website: www.gunnebo.com.my
E-mail: info.my@gunnebo.com

